



- Insulation monitoring and earth fault protection of high tension AC network
- Neutral voltage displacement monitoring
- "Open delta" measuring principle
- Triple relay operation gives more flexibility
- Very fast analogue output signal proportional to meter reading (<50mS), (F-version)

Specifications

Auxiliary Voltage:	100-120, 200-240, 380-415 or 440-460VAC, 40-70Hz (Fuse 0,5A)
Optional aux. Voltage	12, 24, 48 or 110VDC (Fuse 2A)
Input (nom.):	110VAC max
Supply tolerance:	± 10%
Power rating:	1,5VA
Contact rating:	AC: 100VA - 250V/2A max. DC: 50W - 100V/1A max.
Adjustments:	<u>Trip level:</u> <u>Delay:</u>
Warning:	0-100% of alarm level 0-30 sec.
Alarm:	0-100% of FSD 0-30 sec.
Scaling (typical range):	0-50V, 0-150V, 0-250V or 0-500V Other ranges on request.
Analogue Output:	Up to 20mA, max 500R Up to 10V min 100kohm
Temperature:	-20 to +70°C
Weight:	0.64kgs
Front protection:	IP52 (IP65 optional)

Description

KPV14x is a digitally controlled triple zone (two-level) trip relay connected in an "open-delta" configuration. The unit detects changes in the neutral point voltage in a non-grounded high tension network, caused by insulation fault. Often supplied via a step-down transformer.

An auxiliary voltage is required for the unit. A green LED indicates POWER on. Start of monitoring function is delayed when power is switched on (default 2 secs delay). In this way false tripping during power up is avoided. The meter reads the neutral point voltage, and has low-reflection glass to ease reading at a distance. Scale will depend on measuring voltage input and can be customized to nearly any scale.

The triple-zone status LEDs at a glance gives the clear safety message:

- ALARM
- WARNING
- NORMAL

The standard E-version has no analogue output. The F-version has an isolated analogue output signal proportional to meter deflection.

The units three C/O relay outputs are configured for Warning trip (R2), Alarm trip (R1) and trip Status (R3). The trip levels and trip delays are user settable on unit rear to suit most applications. The Status relay is fail to safety configured, and operates when either R1 or R2 trips. Operation of the status trip relay is inverted (fail safe), i.e. the relay is energised during normal conditions.

Dimensions

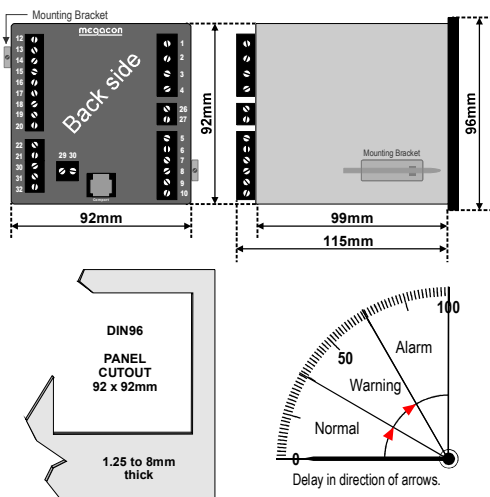

Red relay trip lamps flash instantly (approx. 1 flash per second) on passing a trip. The lamp changes state and the trip relay operates after the pre-set delay. If a trip condition ends during the delay interval, the timer will automatically reset. As standard the unit is supplied for automatic reset.

	Warning	Alarm	Fail safe	Latch
R1		✓		*✓
R2	✓			
R3	✓	✓	✓	*✓

Relays shown de-energised.
R3 is fail-safe and energises when unit is powered.
(E is the standard)

Models	Latch	Output
KPV14E	-	-
KPV14F	-	X
KPV14G*	X	-
KPV14GF*	X	X

Relay Reset
Any latched relay is reset by linking terminals 29 and 30 or by interrupting the voltage input to terminal 1.

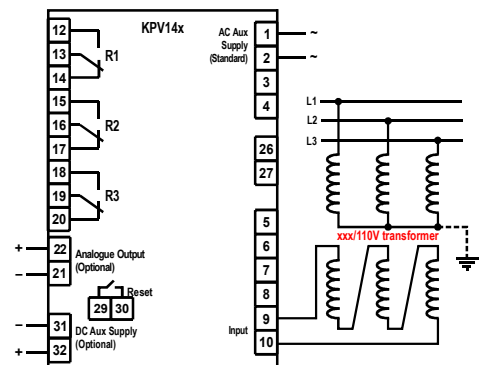

The unit meets EN 61010-1 Cat. III, Pollution degree 2 and the relevant environmental and EMC tests specified in EN 61326-2-4 to comply with the requirements of the major Classification Societies.

The MEGACON policy is one of continuous improvement, consequently equipment supplied may vary in detail from this publication.

ORDERING EXAMPLE:
 Type: KPV14F
 Aux. Supply: 200-240V
 Input: 0-50V
 Range: 0-50V
 Analogue O/P: 4-20mA

