



- Precision Overload Protection, not affected by heavily distorted waveforms
- Total processing time less than 50mS
- 3 or 4-wire systems. Definite time trip delays
- Triple relay operation gives more flexibility
- Optional fast analogue kW-signal output, <50mS
- Wide range setting of high overload contact hysteresis

Specifications

| | |
|--|--|
| Monitored Voltage: | 100-120V, 200-240V, 380-415V, 440-460 or 480VAC 40-70Hz (Fuse 0,5A) |
| Optional Separate Auxiliary Voltage AC: | 100-120V, 200-240V, 380-415V, 440-460 or 480VAC 40-70Hz (Fuse 0,5A) |
| Optional Separate Auxiliary Voltage DC: | 24, 48 or 110VDC (Fuse 2A) <small>(Add nr 2 for models with separate aux. supply. ex: KPW181E2)</small> |
| Supply tolerance: | ± 10% |
| Power rating: | 1,5VA |
| Current Input: | 1 or 5A C.T. <0,1VA |
| Contact rating: | AC: 100VA - 250V/2A max. DC: 50W - 100V/1A max. |
| Adjustments available: | See under Relay Operation (page 2) |
| Analogue outputs: | Up to 20mA, max 500ohm Up to 10VDC, min 100kohm (other outputs available on request) |
| Temperature: | -20 to +70°C |
| Weight: | 0.64kgs |
| Front protection: | IP52 (IP65 optional) |

The unit meets EN 61010-1 Cat. III, Pollution degree 2 and the relevant environmental and EMC tests specified in EN 61326-2-4 to comply with the requirements of the major Classification Societies.

Application

The digitally controlled KPW18x range provides precision (1.0%) overload protection and monitoring of three phase generators or motors.

Available for 3-phase 3-wire (2W3) and 4-wire (3W4) systems.

The unit measures the voltage and current true r.m.s. value, and accuracy is independent of any wave form distortion.

As standard the auxiliary voltage is taken from the unit monitored voltage input. A separate AC or DC auxiliary voltage is optionally available.

A green LED indicates POWER on. Start of monitoring function is delayed when power is switched on (default 2 secs delay). In this way false tripping during power up is avoided.

The DIN96 instrument reads the power level directly in kW. The wattmeter and the triple-zone status LEDs at a glance gives the clear safety message:

- HIGH
- NORMAL
- LOW

OUTPUTS

If output is used for remote meter reading, we recommend 0-1mA for the slave indicator.

Related information:

The KPW18x-range is also available for rail mounting as KCW18x.

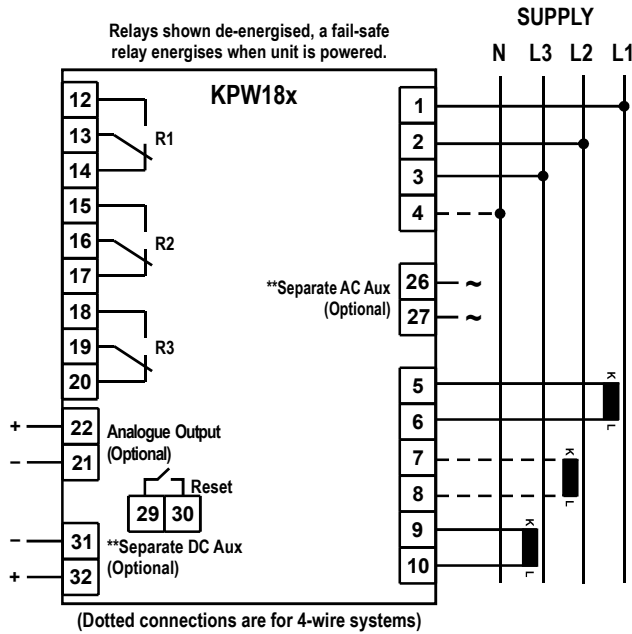

Analogue Output

KPW181F and KPW184F have an analogue output proportional to kW-meter reading. The signal is specifically intended as input to a control system for kW monitoring, load sharing, load shedding etc.

Add to type designation suffix from table below to designate output required:

| | | | |
|------|----------|-------|------------|
| O/P1 | 0 - 10mA | O/P6 | N/A |
| O/P2 | 0 - 20mA | O/P7 | N/A |
| O/P3 | 4 - 20mA | O/P8 | 0 - 10V |
| O/P4 | N/A | O/P9 | 0,2 - 10V |
| O/P5 | N/A | O/P10 | 4,3 - 20mA |

To ensure correct kW measurement voltage phase sequence and CT, connections MUST be as shown on connection diagram.

****Optional separate aux. supply:**
Add nr 2 for models with separate aux. supply. (Example: KPW181E2)

Description

KPW181E - KPW181F

Both relays can be used for non-essential load release or as a start/stop signal to a standby generator etc. A wide range overload contact hysteresis can be set to enable R2 to be used for a non-essential load to be reconnected or as a standby generator stop signal. Relay R3 is an additional relay that can be used for local indication, as an input to an alarm system etc.

A trip LED flashes when the trip level is passed, the relay trips when the delay has elapsed. The timer resets if the fault is removed during countdown. The High/Low relays can be used to regulate power in AC systems.

Relay Operation

Configuration: 3-Phase, 3-Wire (2W3)

| | LOW | HIGH | N/A | Fail Safe | Latch | Fixed Hysteresis | Adjustable Hysteresis |
|----|-----|------|-----|-----------|-------|------------------|-----------------------|
| R1 | ✓ | | | ✓ | | ✓ | |
| R2 | | ✓ | | ✓ | | | ✓ |
| R3 | ✓ | ✓ | | | | | |

| Model | Latch | Output |
|---------|-------|--------|
| KPW181E | - | - |
| KPW181F | - | X |

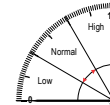

| Adjustments | Trip level | Delay |
|------------------|-----------------|----------|
| High: | 0-100% of FSD | 0-30secs |
| Low: | 0-100% of FSD | 0-30secs |
| Hysteresis High: | 2-50% of FSD | |
| Hysteresis Low: | Fixed 2% of FSD | |

KPW184E - KPW184F

Both relays can be used for non-essential load release or as a start/stop signal to a standby generator etc. A wide range overload contact hysteresis can be set to enable R2 to be used for a non-essential load to be reconnected or as a standby generator stop signal. Relay R3 is an additional relay that can be used for local indication, as an input to an alarm system etc.

A trip LED flashes when the trip level is passed, the relay trips when the delay has elapsed. The timer resets if the fault is removed during countdown. The High/Low relays can be used to regulate power in AC systems.

Configuration: 3-Phase, 4-Wire (3W4)

| | LOW | HIGH | N/A | Fail Safe | Latch | Fixed Hysteresis | Adjustable Hysteresis |
|----|-----|------|-----|-----------|-------|------------------|-----------------------|
| R1 | ✓ | | | ✓ | | ✓ | |
| R2 | | ✓ | | ✓ | | | ✓ |
| R3 | ✓ | ✓ | | | | | |

| Model | Latch | Output |
|---------|-------|--------|
| KPW184E | - | - |
| KPW184F | - | X |

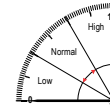

| Adjustments | Trip level | Delay |
|------------------|-----------------|----------|
| High: | 0-100% of FSD | 0-30secs |
| Low: | 0-100% of FSD | 0-30secs |
| Hysteresis High: | 2-50% of FSD | |
| Hysteresis Low: | Fixed 2% of FSD | |

Dimensions

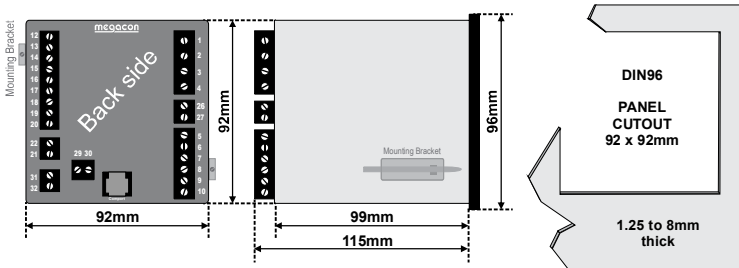

The MEGAICON policy is one of continuous improvement, consequently equipment supplied may vary in detail from this publication.

ORDERING EXAMPLE:
Type: KPW181F
Aux. Supply: 200-240VAC
Monitored Voltage: 440VAC
Input Current: 1500/5A
Range: 0-1500kW
Analogue O/P: 4,3-20mA

Relay Configurations

The relay operation is delayed in the arrow direction, the reset is instantaneous.

Both trip levels can, independently, individually set over the scale range (0-100% FSD).

